

SOLLEVATORI OLEOPNEUMATICI A CARRELLO

PNEUMATIC TROLLEY JACK

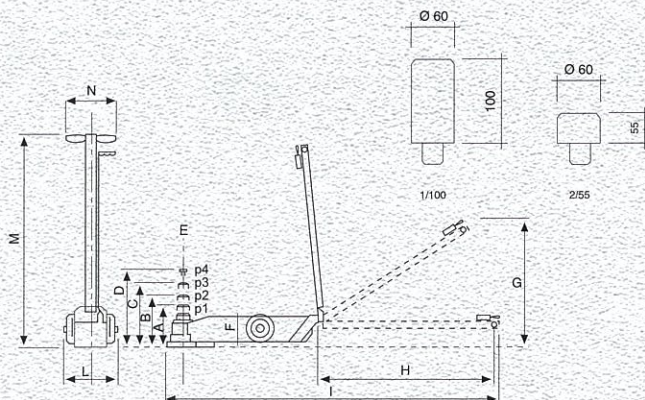

ACCESSORI IN DOTAZIONE
SET OF EQUIPMENT

| TIPO TYPE | PORTATA CAPACITY TON. | | | | ALTEZZA MINIMA MINIM. HEIGHT MM. | A | B | C | D | E | F | G | H | I | L | M | N | PESO WEIGHT KG. |
|--------------|-----------------------------|-----|-----|-----|--|-----|-----|-----|-----|-----|-----|-----|------|------|-----|------|-----|-----------------------|
| | P.1 | P.2 | P.3 | P.4 | | | | | | | | | | | | | | |
| O.P. 203 | 60 | 30 | 20 | - | 180 | 248 | 311 | 397 | - | 110 | 155 | 800 | 1180 | 2210 | 340 | 1400 | 300 | 88 |
| O.P. 114 | 60 | 30 | 20 | 11 | 180 | 248 | 311 | 397 | 477 | 110 | 155 | 800 | 1180 | 2210 | 340 | 1400 | 300 | 90 |
| O.P. 154 | 75 | 40 | 30 | 15 | 146 | 205 | 253 | 290 | 358 | 110 | 155 | 400 | 1400 | 2470 | 340 | 1620 | 300 | 100 |

STUDIATI E REALIZZATI PER FACILITARE IL SOLLEVAMENTO SENZA SFORZO DI GRANDI PORTATE. STRUTTURA SOLIDA E LARGA BASE DI APPOGGIO GARANTISCONO ESTREMA STABILITA' IN TUTTE LE POSIZIONI DI LAVORO.

DOTATO DI DISPOSITIVO DI SICUREZZA PER IMPEDIRE LA DISCESA DEL CILINDRO IN CASO DI MANCANZA D'ARIA.

VALVOLA DI SOVRACCARICO E DISCESA PNEUMATICA A DEPRESSIONE.

MANICO REGOLABILE A TRE POSIZIONI. PRESSIONE D'ESERCIZIO BAR 8-10. ATTACCO ENTRATA ARIA 1/4" GAS.

IL MODELLO O.P. 203 E O.P. 154 È FORNITO COMPLETO DI PROLUNGHE STANDARD.

DESIGNED AND DEVELOPED TO MAKE EASY LIFTING OF GREAT CAPACITY. STRONG BODY AND LARGE SURFACE ENSURE THE MAXIMUM STABILITY IN ALL WORKING CONDITIONS. PROVIDED WITH SAFETY DEVICE TO AVOID THE DESCENT IN CASE OF AIR PRESSURE LACK. SUPPLIED WITH AUTOMATIC OVERLOAD SAFETY VALVE. DESCENT CONTROLLED BY A PNEUMATIC VACUUM SYSTEM. THREE POSITION ADJUSTING HANDLE. WORKING PRESSURE 8 - 10 BAR. AIR INLET 1/4" GAS. THE MODEL O.P. 203 AND O.P. 154 IS SUPPLIED WITH TWO EXTENSION PLATES.

